

## ST-LINK/V2 in-circuit debugger/programmer for STM8 and STM32

---

### Introduction

The ST-LINK/V2 is an in-circuit debugger/programmer for the STM8 and STM32 microcontroller families. The single wire interface module (SWIM) and JTAG/serial wire debugging (SWD) interfaces, facilitate communication with any STM8 or STM32 microcontroller located on an application board.

In addition to providing the same functionalities as the ST-LINK/V2, the ST-LINK/V2-ISOL features digital isolation between the PC and the target application board. It also withstands voltages of up to 2500 VRMS.

The USB full-speed interface allows communication with a PC and:

- STM8 devices via ST Visual Develop (STVD) or ST Visual Program (STVP) software (which are available from STMicroelectronics)
- STM32 devices via Atollic, IAR, Keil, and TASKING integrated development environments.

**Table 1. Applicable tools**

Type	Part number	Order Code	Description
Development tools	ST-LINK/V2	ST-LINK/V2	In-circuit debugger/programmer
		ST-LINK/V2ISOL	In-circuit debugger/programmer with digital isolation

**Figure 1. ST-LINK/V2 and ST-LINK/V2-ISOL**

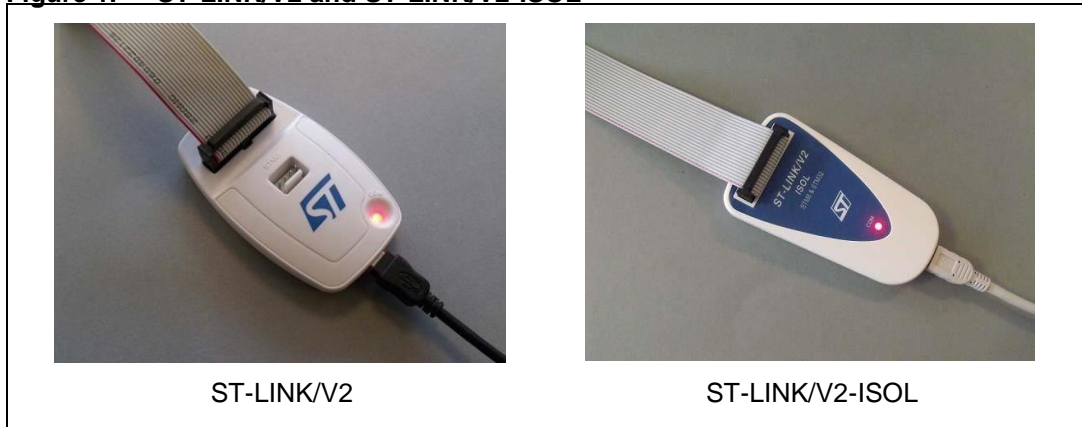

## 1 Features

- 5 V power supplied by a USB connector
- USB 2.0 full speed compatible interface
- USB standard A to mini B cable
- SWIM specific features
  - 1.65 V to 5.5 V application voltage supported on SWIM interface
  - SWIM low-speed and high-speed modes supported
  - SWIM programming speed rate: 9.7 Kbytes/s in low speed and 12.8 Kbytes/s in high speed
  - SWIM cable for connection to the application via an ERNI standard vertical (ref: 284697 or 214017) or horizontal (ref: 214012) connector
  - SWIM cable for connection to the application via a pin header or a 2.54 mm pitch connector
    - JTAG/serial wire debugging (SWD) specific features
  - 1.65 V to 3.6 V application voltage supported on the JTAG/SWD interface and 5 V tolerant inputs
  - JTAG cable for connection to a standard JTAG 20-pin pitch 2.54 mm connector
  - Supports JTAG communication
  - Supports serial wire debug (SWD) and serial wire viewer (SWV) communication
    - Direct firmware update feature supported (DFU)
    - Status LED which blinks during communication with the PC
    - 2500 VRMS high isolation voltage (ST-LINK/V2-ISOL only)
    - Operating temperature 0 to 50 °C

## 2 Product contents

Figures [ST-LINK/V2 product contents](#) show the various cables delivered within the product. They include (from left to right in [Figure 2](#) and [Figure 3](#)):

- USB standard A to mini B cable (A)
- ST-LINK/V2 debugging and programming (B)
- SWIM low-cost connector (C)
- SWIM flat ribbon with a standard ERNI connector at one end (D)
- JTAG or SWD and SWV flat ribbon with a 20-pin connector (E)

Figure 2. ST-LINK/V2 product contents



Product contents

Figure 3. ST-LINK/V2-ISOL product contents



## 3 Hardware configuration

The ST-LINK/V2 is designed around the STM32F103C8 device which incorporates the high-performance ARM®, Cortex™-M3 core. It is available in a TQFP48 package.

As shown in [Figure 4](#), the ST-LINK/V2 provides two connectors:

- an STM32 connector for the JTAG/SWD and SWV interface
- an STM8 connector for the SWIM interface

The ST-LINK/V2-ISOL provides one connector for the STM8 SWIM, STM32 JTAG/SWD and SWV interfaces.

**Figure 4. Connectors of the ST-LINK/V2 and ST-LINK/V2-ISOL**



1. A = STM32 JTAG and SWD target connector
2. B = STM8 SWIM target connector
3. C = STM8 SWIM, STM32 JTAG and SWD target connector
4. D = Communication activity LED

### 3.1 Connection with STM8 applications

For STM8 developments, the ST-LINK/V2 can be connected to the target board by two different cables, depending on the connector available on the application board.

These cables are:

- SWIM flat ribbon with a standard ERNI connector at one end
- SWIM cable with two 4-pin, 2.54 mm connector or SWIM separate-wires cable

#### 3.1.1 Standard ERNI connection with SWIM flat ribbon

[Figure 5](#) shows how to connect the ST-LINK/V2 if a standard ERNI 4-pin SWIM connector is present on the application board.

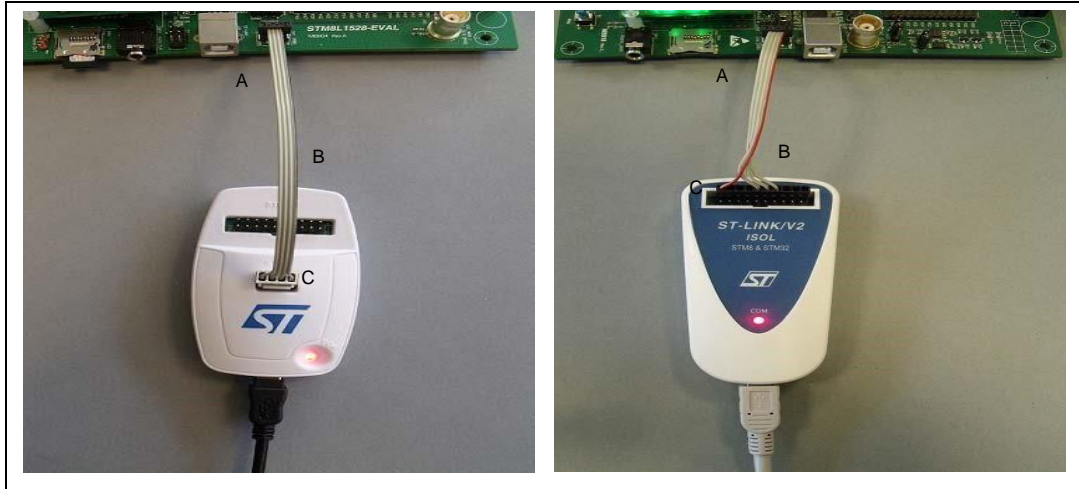
**Figure 5. ERNI connection**

1. A = Target application board with ERNI connector
2. B = Wire cable with ERNI connector at one end
3. C = STM8 SWIM target connector
4. See [Figure 11: SWIM ST-LINK/V2 standard ERNI cable](#).

[Figure 6](#) shows that pin 16 is missing on the ST-LINK/V2-ISOL target connector. This missing pin is used as a safety key on the cable connector to guarantee connection of the SWIM cable in the correct position on the target connector even pins, used for both SWIM and JTAG cables.

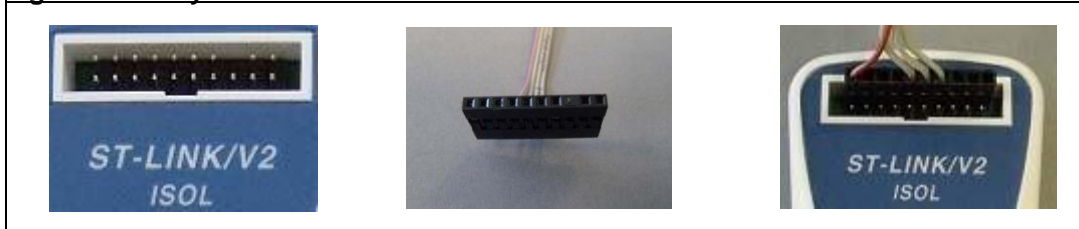
**Figure 6. Key detail on connectors**

### 3.1.2 Low-cost SWIM connection

[Figure 7](#) shows how to connect the ST-LINK/V2 if a 4-pin, 2.54 mm, low-cost SWIM connector is present on the application board.

Figure 7. Low-cost connection

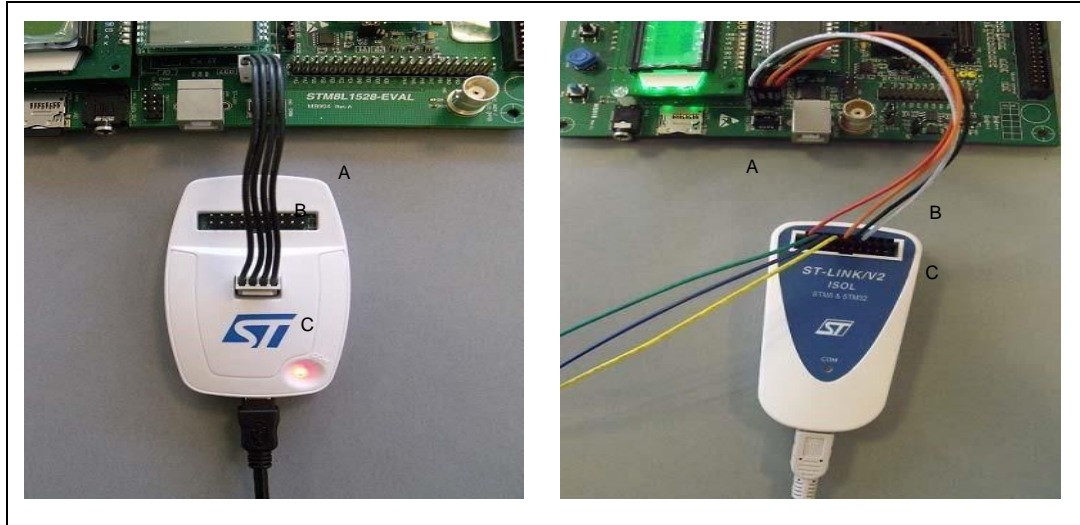

1. A = Target application board with 4-pin, 2.54 mm, low-cost connector
2. B = Wire cable with a 4-pin connector or separate-wires cable
3. C = STM8 SWIM target connector
4. See [Figure 12: SWIM ST-LINK/V2 low-cost cable](#)

### 3.1.3 SWIM signals and connections

[Table 2](#) summarizes the signal names, functions, and target connection signals using the wire cable with a 4-pin connector.

Table 2. SWIM flat ribbon connections for ST-LINK/V2

Pin no.	Name	Function	Target connection
1	VDD	Target VCC <sup>(1)</sup>	MCU VCC
2	DATA	SWIM	MCU SWIM pin
3	GND	GROUND	GND
4	RESET	RESET	MCU RESET pin

1. The power supply from the application board is connected to the ST-LINK/V2 debugging and programming board to ensure signal compatibility between both boards.

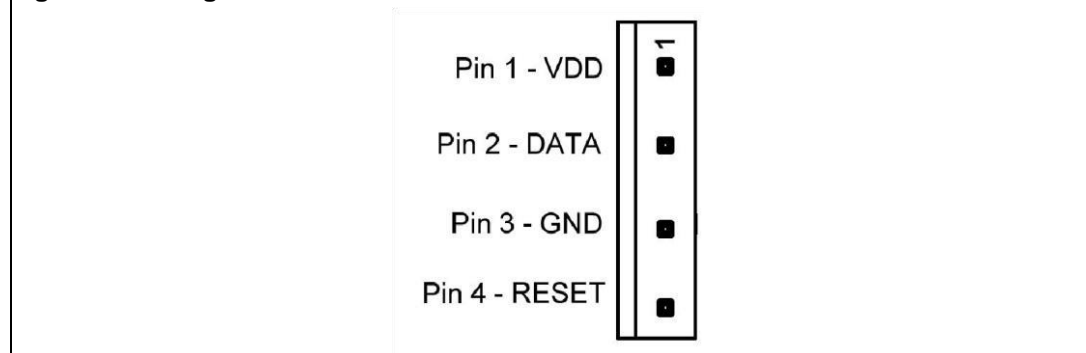
**Figure 8. Target SWIM connector**

[Table 3](#) summarizes the signal names, functions, and target connection signals using the separate-wires cable.

As the SWIM separate-wires cable has independent connectors for all pins on one side, it is possible to connect the ST-LINK/V2-ISOL to an application board without a standard SWIM connector. On this flat ribbon, all signals are referenced by a specific color and a label to ease the connection on target.

**Table 3. SWIM low-cost cable connections for ST-LINK/V2-ISOL**

Color	Cable pin name	Function	Target connection
Red	TVCC	Target VCC <sup>(1)</sup>	MCU VCC
Green	UART-RX	Unused	Reserved <sup>(2)</sup> (not connected on the target board)
Blue	UART-TX		
Yellow	BOOT0		
Orange	SWIM	SWIM	MCU SWIM pin
Black	GND	GROUND	GND
White	SWIM-RST	RESET	MCU RESET pin

1. The power supply from the application board is connected to the ST-LINK/V2 debugging and programming board to ensure signal compatibility between both boards.

2. BOOT0, UART-TX and UART-RX are reserved for future developments.

TVCC, SWIM, GND and SWIM-RST can be connected to a low-cost 2.54 mm pitch connector or to pin headers available on the target board.

## 3.2 **Connection with STM32 applications**

For STM32 developments, the ST-LINK/V2 needs to be connected to the application using the standard 20-pin JTAG flat ribbon provided.

[Table 4](#) summarizes the signals names, functions, and target connection signals of the standard 20-pin JTAG flat ribbon.

**Table 4. JTAG/SWD cable connections**

Pin no.	ST-LINK/V2 connector (CN3)	ST-LINK/V2 function	Target connection (JTAG)	Target connection (SWD)
1	VAPP	Target VCC	MCU VDD <sup>(1)</sup>	MCU VDD <sup>(1)</sup>
2				
3	TRST	JTAG TRST	JNTRST	GND <sup>(2)</sup>
4	GND	GND	GND <sup>(3)</sup>	GND <sup>(3)</sup>
5	TDI	JTAG TDO	JTDI	GND <sup>(2)</sup>
6	GND	GND	GND <sup>(3)</sup>	GND <sup>(3)</sup>
7	TMS_SWDIO	JTAG TMS, SW IO	JTMS	SWDIO
8	GND	GND	GND <sup>(3)</sup>	GND <sup>(3)</sup>
9	TCK_SWCLK	JTAG TCK, SW CLK	JTCK	SWCLK
10	GND	GND	GND <sup>(3)</sup>	GND <sup>(3)</sup>
11	NC	Not connected	Not connected	Not connected
12	GND	GND	GND <sup>(3)</sup>	GND <sup>(3)</sup>
13	TDO_SWO	JTAG TDI, SWO	JTDO	TRACESWO <sup>(4)</sup>
14	GND	GND	GND <sup>(3)</sup>	GND <sup>(3)</sup>
15	NRST	NRST	NRST	NRST
16	GND	GND	GND <sup>(3)</sup>	GND <sup>(3)</sup>
17	NC	Not connected	Not connected	Not connected
18	GND	GND	GND <sup>(3)</sup>	GND <sup>(3)</sup>
19	VDD	VDD (3.3V) <sup>(5)</sup>	Not connected	Not connected
20	GND	GND	GND <sup>(3)</sup>	GND <sup>(3)</sup>

1. The power supply from the application board is connected to the ST-LINK/V2 debugging and programming board to ensure signal compatibility between both boards.

2. Connect to GND for noise reduction on the ribbon.
3. At least one of this pin must be connected to the ground for correct behavior (connecting all of them is recommended).
4. Optional: for Serial Wire Viewer (SWV) trace.
5. Available on ST-LINK/V2 only and not connected on ST-LINK/V2/OPTO.

Figure 9 shows how to connect the ST-LINK/V2 to a target using the JTAG cable.

**Figure 9. JTAG and SWD connection**

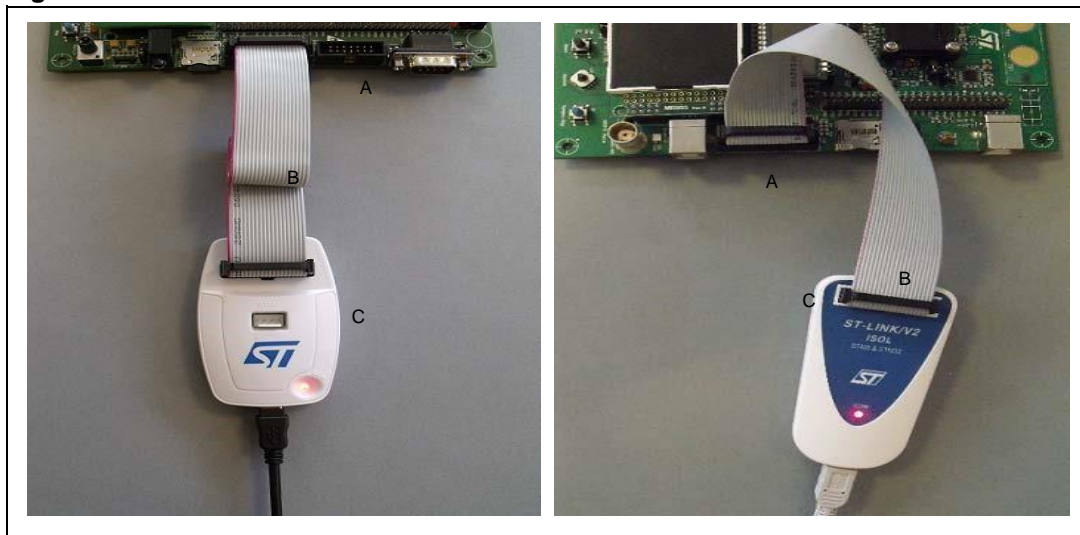

1. A = Target application board with JTAG connector
2. B = JTAG/SWD 20-wire flat cable
3. C= STM32 JTAG and SWD target connector

The reference of the connector needed on the target application board is:  
2x10C header wrapping 2x40C H3/9.5 (pitch 2.54) - HED20 SCOTT PHSD80.

**Figure 10. JTAG debugging flat ribbon layout**

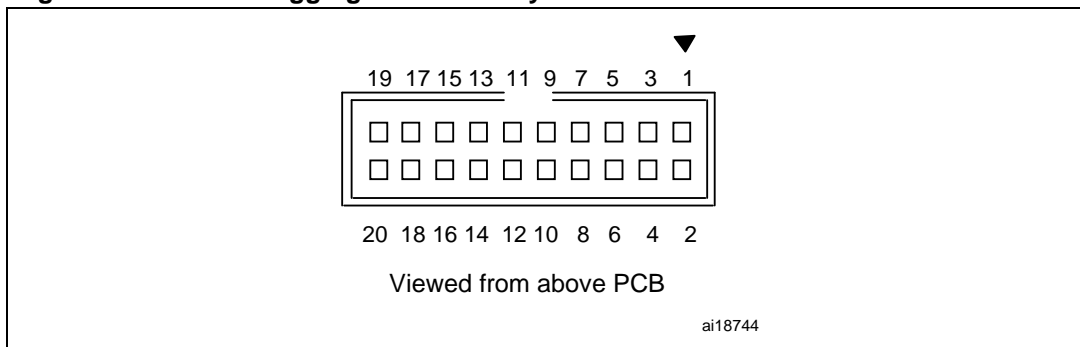

**Note:** For low cost applications or when the standard 20 pins pitch 2.54mm connector footprint is too big, it is possible to implement the Tag-Connect solution to save cost and space on the application board. The Tag-Connect adapter and cable provide a simple reliable means of connecting ST-LINK/V2 or ST-LINK/V2-ISOL to your PCB without requiring a mating component on application PCB. For more details on this solution and application PCB footprint information, please visit [www.Tag-Connect.com](http://www.Tag-Connect.com).

The references of components compatible with JTAG and SWD interfaces are:

- a) TC2050-ARM2010 adapter (20pins to 10pins interface board)

- b) TC2050-IDC or TC2050-IDC-NL (No Legs) (10pins cable)
- c) TC2050-CLIP retaining clip for use with TC2050-IDC-NL (optional)

### 3.3 ST-LINK/V2 status LEDs

The LED labeled 'COM' on top of the ST-LINK/V2 shows the ST-LINK/V2 status (whatever the connection type).

When the:

- LED is blinking RED: the first USB enumeration with the PC is taking place.
- LED is RED: communication between the PC and ST-LINK/V2 is established (end of enumeration).
- LED is blinking GREEN/RED: data are being exchanged between the target and the PC.
- LED is GREEN: the last communication has been successful.
- LED is ORANGE: ST-LINK/V2 communication with the target has failed.

## 4 Software configuration

### 4.1 ST-Link/V2 firmware upgrade

The ST-Link/V2 embeds a firmware upgrade mechanism for in-situ upgrade through the USB port. As the firmware might evolve during the whole life of the ST-Link/V2 product (new functionality, bug fixes, support for new microcontroller families ...), it is recommended to visit [www.st.com/stlinkv2](http://www.st.com/stlinkv2) periodically in order to stay up-to-date with the latest firmware version.

### 4.2 STM8 application development

Please refer to ST toolset Pack24 with Patch 1 or more recent, which includes ST Visual Develop (STVD) and ST Visual Programmer (STVP).

### 4.3 STM32 application development and Flash programming

Third party toolchains, Atollic TrueSTUDIO, IAR EWARM, Keil MDK-ARM, and TASKING VX-toolset support ST-LINK/V2 according to the versions given in [Table 5](#) or the most recent version available.

**Table 5. How third party toolchains support ST-LINK/V2**

Third party	Toolchain	Version
Atollic	TrueSTUDIO	2.1
IAR	EWARM	6.20
Keil	MDK-ARM	4.20
TASKING	VX-toolset for ARM Cortex-M	4.0.1

The ST-LINK/V2 requires a dedicated USB driver. If the toolset installed it automatically, file *stlink\_winusb.inf* is installed in <WINDIR>/inf (where <WINDIR> is typically C:/Windows).

If the toolset setup did not install it automatically, the driver can be found on [www.st.com](http://www.st.com):

1. Connect to [www.st.com](http://www.st.com).
2. In the search tab, part number field, look for **ST-Link/V2**.
3. Click on the **Generic Part Number** column's hyperlink to ST-Link/V2.
4. In the **Design support** tab, **SW drivers** section, click on the icon to download *stlink\_v2\_usbdriver.zip*.
5. Unzip and run *ST-Link\_V2\_USBdriver.exe*.

For more information on third party tools, please visit:

- [www.atollic.com](http://www.atollic.com)
- [www.iar.com](http://www.iar.com)
- [www.keil.com](http://www.keil.com)
- [www.tasking.com](http://www.tasking.com) **Schematics**

## 5 Schematics

Figure 11. SWIM ST-LINK/V2 standard ERNI cable

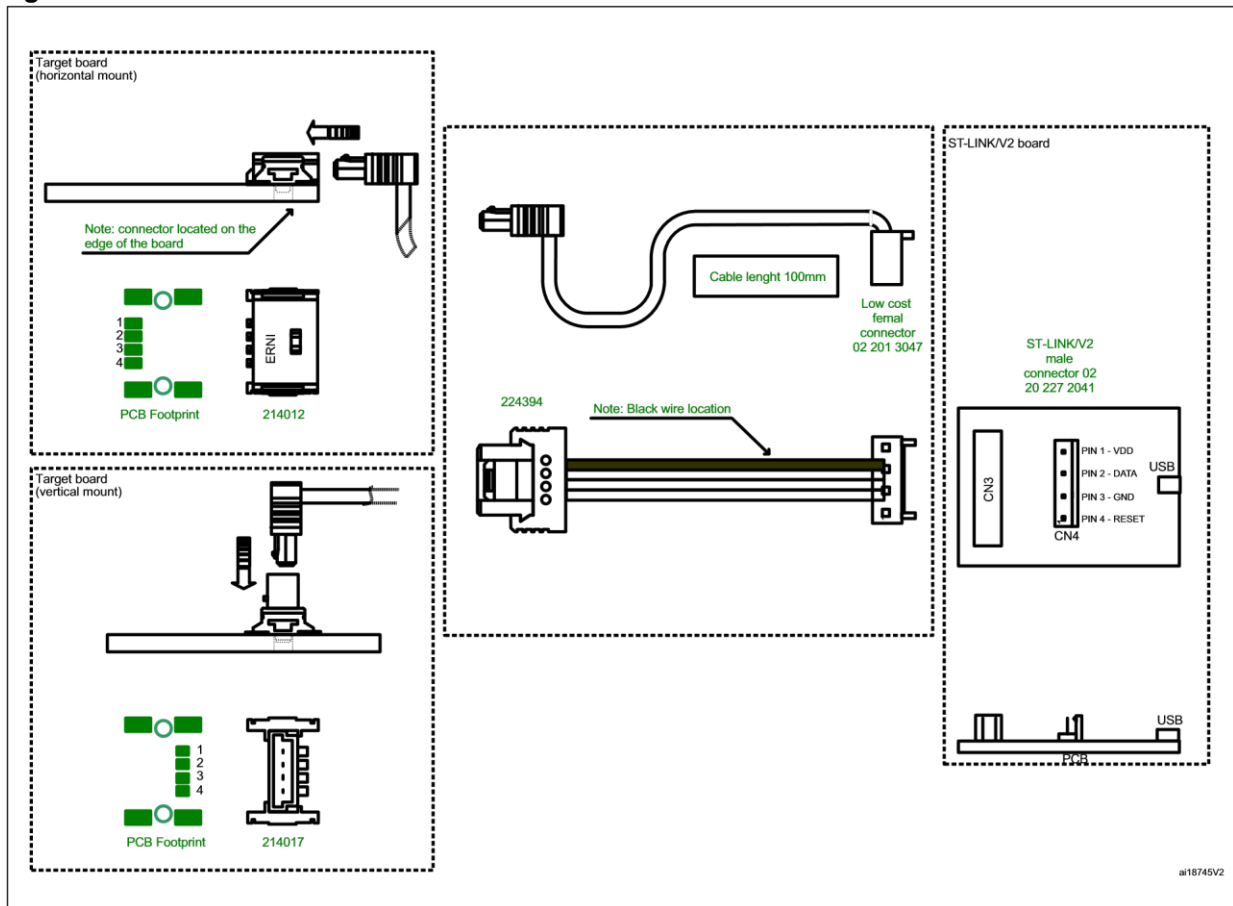

- Legend for pin descriptions: VDD = Target voltage sense  
 DATA = SWIM DATA line between target and debug tool  
 GND = Ground voltage  
 RESET = Target system reset

Figure 12. SWIM ST-LINK/V2 low-cost cable

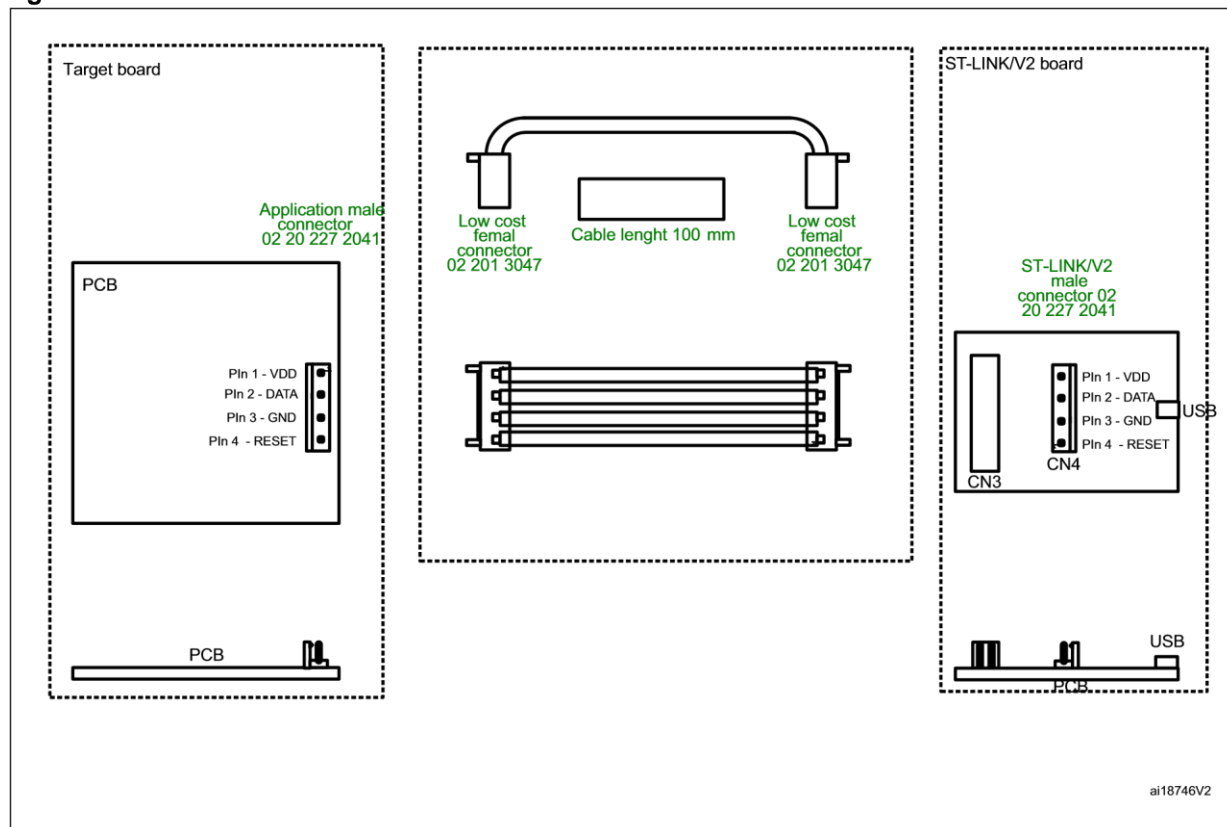

- Legend for pin descriptions: VDD = Target voltage sense  
 DATA = SWIM DATA line between target and debug tool  
 GND = Ground voltage  
 RESET = Target system reset

**Revision history**

## 6 Revision history

Table 6. Document revision history

Date	Revision	Changes
22-Apr-2011	1	Initial release.
03-Jun-2011	2	<p><i>Table 2: SWIM flat ribbon connections for ST-LINK/V2:</i> added footnote 1 to the function "Target VCC".</p> <p><i>Table 4: JTAG/SWD cable connections:</i> added footnote to the function "Target VCC".</p> <p><i>Table 5: How third party toolchains support ST-LINK/V2:</i> updated the "Versions" of IAR and Keil.</p>

19-Aug-2011	3	Added USB driver details to <a href="#">Section 4.3</a> .
11-May-2012	4	Added SWD and SWV to JTAG connection features. Modified <a href="#">Table 4: JTAG/SWD cable connections</a> .
13-Sep-2012	5	Added ST-LINK/V2-ISOL order code. Updated <a href="#">Section 4.1: STM8 application development on page 15</a> Added Note 5 in <a href="#">Table 4</a> . Added Note "For low cost applications..." before <a href="#">Section 3.3: STLINK/V2 status LEDs on page 14</a>
18-Oct-2012	6	Added <a href="#">Section 4.1: ST-Link/V2 firmware upgrade on page 15</a> .

---